

1. General Specification

1	Model No.	Mirage 80x15S
2	Dimension of fan	80*80*15MM
3	Voltage	12V (10.8-13.2V)
4	Starting voltage	7.0V (POWER ON/OFF)
5	Power consumption	1.8W
6	Rated current	0.15A(Safety)
7	Speed	2,500±10%R.P.M. At 25 °C, After 3~5 minutes rotating (Fan alone).
8	Max air flow	23.8CFM
9	Air Pressure	1.7mm-H ₂ O
10	Noise	29 dBA

2. Main Parts Specification

1	Fan Blade & Frame	PBT BLACK
2	Bearing	Sleeve Bearing
3	P.C.B	One layer PC Board
4	Enameled Wire	2UEW
5	Silicon Steel Strip	H23
6	Lead Wire	UL1061 26AWG L=300±10MM (-)BLACK (+)RED (FG)YELLOW
7	Connector	2510-3P

3. Electrical and Environmental Specification

1	Expected Life	30,000 hrs,25
2	Rotating Direction	Anti-Clockwise
3	No. of pole	4Poles
4	Operating Temp .Range	Temperature:-10 ~+70 Humidity:35%~85%RH
5	Store Temperature	Temperature:-40 ~+70 Humidity:35%~85%RH

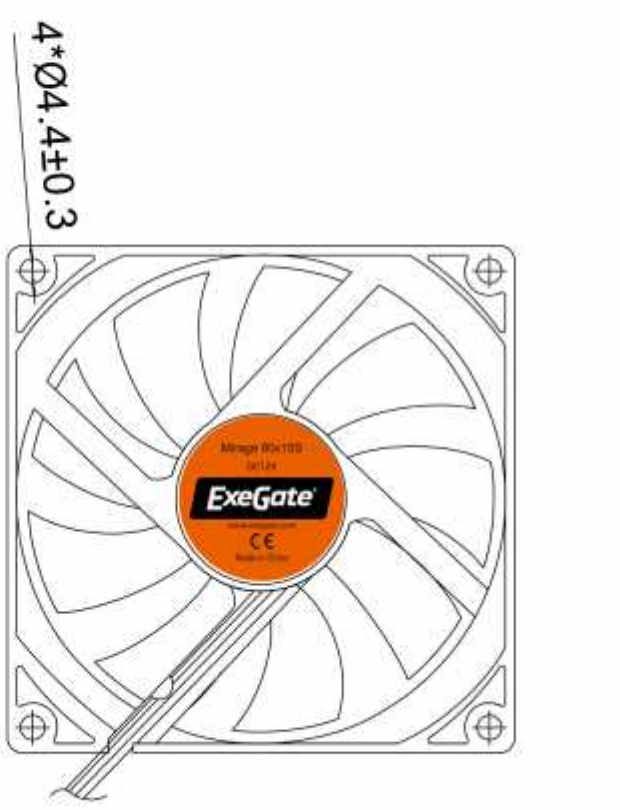
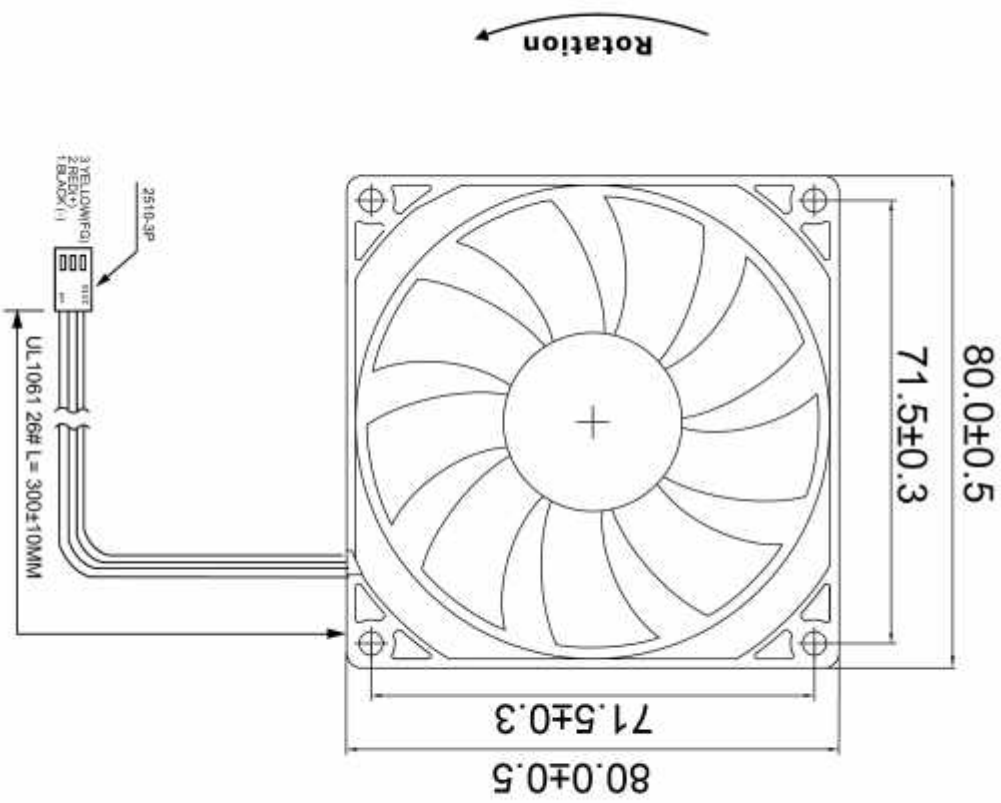

Unit: (mm)

Voltage	12 V
Safety Current	0.15 A
Bearing	Sleeve bearing
Speed	2,500±10%/RPM
Connector	2510-3P
Wire 1	BLACK(-) 26# UL1061
Wire 2	RED(+) 26# UL1061
Wire 3	YELLOW(FG) 26# UL1061