

1. General Specification

1	Model No.	Mirage-H 120x120x25H
2	Dimension of fan	120*120*25MM
3	Voltage	12V (10.8-13.2V)
4	Starting voltage	7.0V (POWER ON/OFF)
5	Power consumption	2.4W
6	Rated current	0.23A(Safety)
7	Speed	1,200±10%R.P.M. At 25℃,After 3~5 minutes rotating (Fan alone).
8	Max air flow	50.44CFM
9	Air Pressure	1.9mm-H ₂ O
10	Noise	23 dBA

2. Main Parts Specification

1	Fan Blade & Frame	PBT BLACK
2	Bearing	Hydraulic Bearing
3	P.C.B	One layer PC Board
4	Enameled Wire	2UEW
5	Silicon Steel Strip	H23
6	Lead Wire	UL2468 26AWG L=400±10MM (-)BLACK (+)RED (FG)YELLOW
7	Connector	2510-3P

3. Electrical and Environmental Specification

1	Expected Life	40,000 hrs,25℃
2	Rotating Direction	Anti-Clockwise
3	No. of pole	4Poles
4	Operating Temp .Range	Temperature:-10℃~+70℃ Humidity:35%~85%RH
5	Store Temperature	Temperature:-40℃~+70℃ Humidity:35%~85%RH

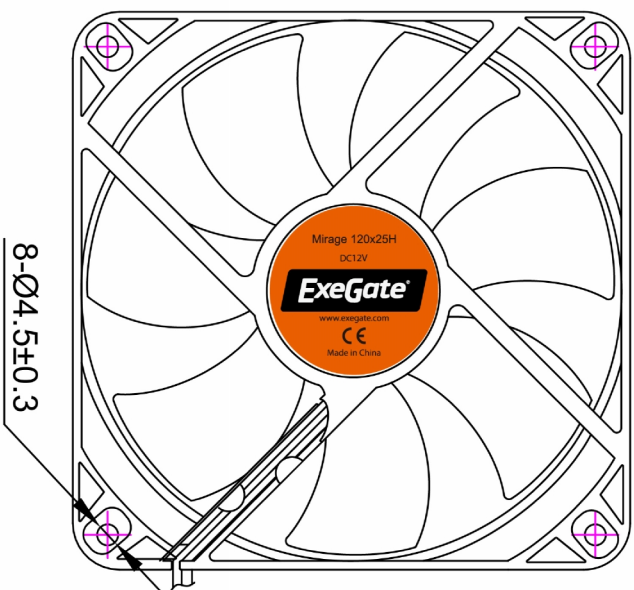
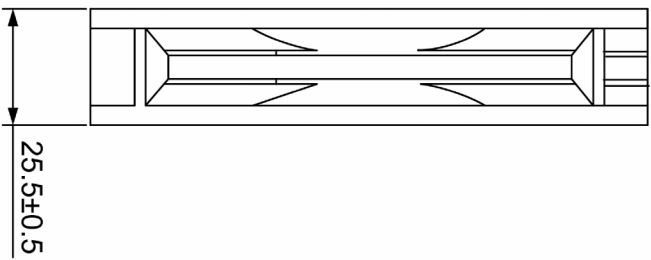
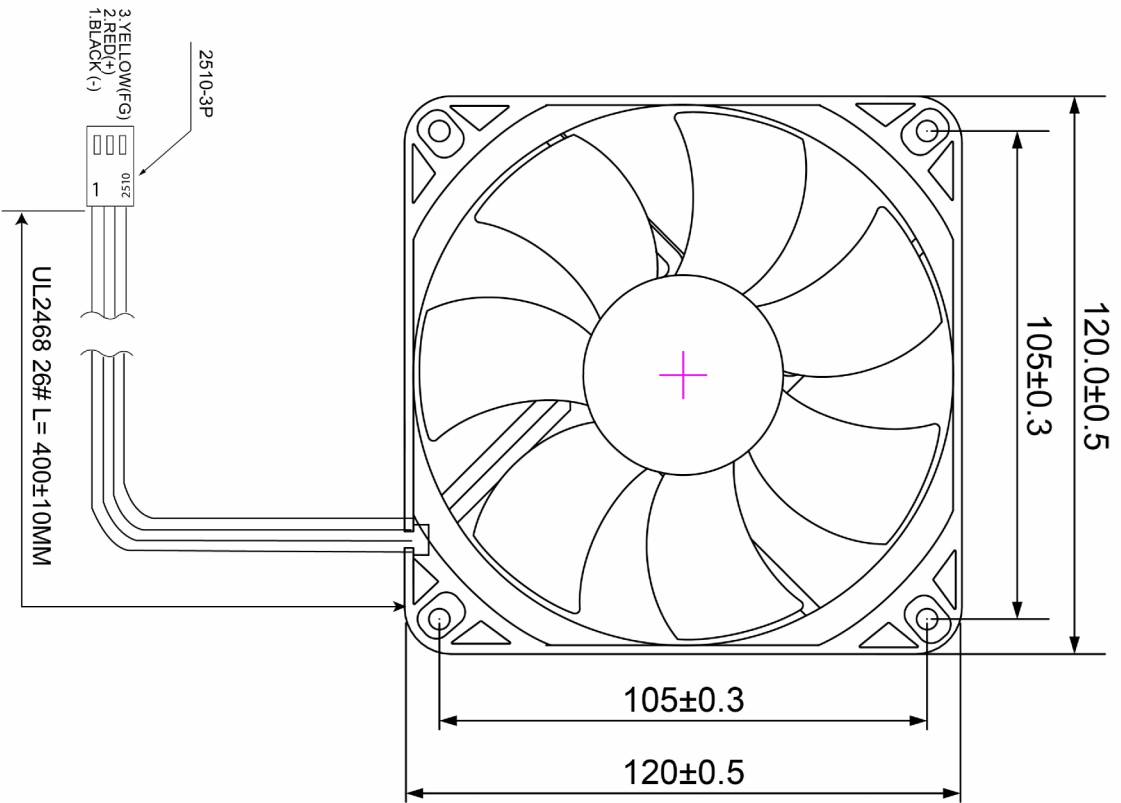

Unit: (mm)

Voltage	12 V
Safety Current	0.23 A
Bearing	Hydraulic bearing
Speed	1,600±10%/RPM
Connector	2510-3P
Wire 1	BLACK (-) 26# UL2468
Wire 2	RED(+) 26# UL2468
Wire 3	YELLOW(FG) 26# UL2468